



ProDrive® Plastics & Composites ***Cap Block - Pile Drive Hammer Cushion Pads*** ***from Professional Plastics, Inc.***

ProDrive® Cushion Pads for Pile Driving

Cushion pads are used to improve the pile-driving process, a common activity in the construction of large structures such as bridges and buildings. Piles—heavy beams of concrete, steel, or other material—are pounded into the ground by a large "hammer" attached to a crane. The cushion pad, which sits inside a "helmet" placed between the hammer and the pile, must transmit force while protecting the pile.

Cushion Pads have proven themselves in all types of pile driving applications. Professional Plastics has the ability to cut pads to your specifications on our CNC Router. Hammer cushion pads have to be strong to withstand the pounding and to transmit the driving force needed while protecting your equipment and the pile. Hammer cushion pads extend the life of your hammer while transmitting the maximum striking force to the pile.

Made of high impact Phenolic Material, or Impact Resistant Cast Nylon, these cushion pads will absorb the initial hammer shock while transferring the power that you need to the helmet and into the pile. By absorbing this initial hammer shock, these cushion pads reduce the tremendous wear and stress hammers are subjected to, thereby, minimizing breakdowns and nonproductive downtimes. Damage to the contact point of the pile is also lessened often making it unnecessary to trim the pile which can be a time consuming and costly procedure.

ProDrive® Canvas Phenolic Cushion Pads provide tremendous impact resistance and stability while absorbing shock. Canvas phenolic is made from a medium weave cotton cloth fabric and mixed with phenolic resins to provide good wear resistance, low moisture absorption, and good mechanical strength at economical cost.

ProDrive Nylon-Based Products

These materials are chemically formulated copolymers designed to offer an engineering material with the High Tensile and Compressive properties of Cast Nylon, with the impact and wear resistance of polyurethane. The unfilled, or "natural" grade of material, is yellow in color and displays exceedingly high impact resistance and tensile properties. Use considerations include environments with: Shock, Abrasion, Vibration, Impact & Moisture absorption.

- **ProDrive® GP: Color: Yellow**

The unfilled, or "natural" grade of material, is yellow in color and displays exceedingly high impact resistance and tensile properties. Use considerations include environments with: Shock, Abrasion, Vibration, Impact & Moisture absorption.

- **ProDrive® Oil: Color: Olive Green**

Using the same proprietary process as our Protech Oil, our liquid lubrication impregnated within the polymer chain offers excellent surface lubricity. In addition to the advantages of Protech GP, use considerations for Protech Oil includes the following environments: Increased Wear, Moisture Absorption, Increased Abrasion.

- **ProDrive® SL: Color: Light Grey**

The impact resistance of the Protech copolymer with the wear resistance of Protech SL (solid lubricant) result in the longest lasting material for the most aggressive industrial applications. Use considerations include: Extreme Wear, Extreme Abrasion

Pile Driving System

Various parts of the Pile Driving System.

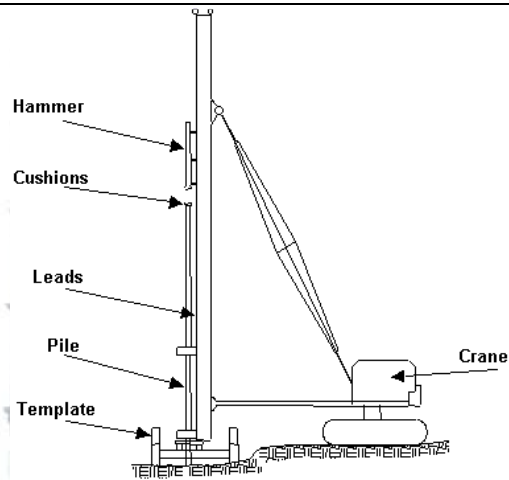

It is important that you know and recognize the various components as in many cases it is part of your responsibility to verify that the proper equipment is on site, operates properly or is not damaged.

Cushions

Cushions are used to protect both the hammer and the pile. Cushions that protect the hammer are called capblock cushions or hammer cushions. Cushions used to protect the pile are called pile cushions.

Capblock (Hammer Cushion Pads)

Hammer Cushions Pads are constructed of man-made materials that are heat resistant, durable and absorb a certain amount of shock. Common types of materials are Aluminum, Micarta (ProDrive® Phenolic) and Polymer (ProDrive® Nylon) which are in the form of disks. Aluminum is usually 1/2 inch thick. Micarta is usually 1 inch thick and are used in sandwich form. Polymer is typically used alone.

Hammer cushions are located between the point of the ram or anvil and the pile cap.

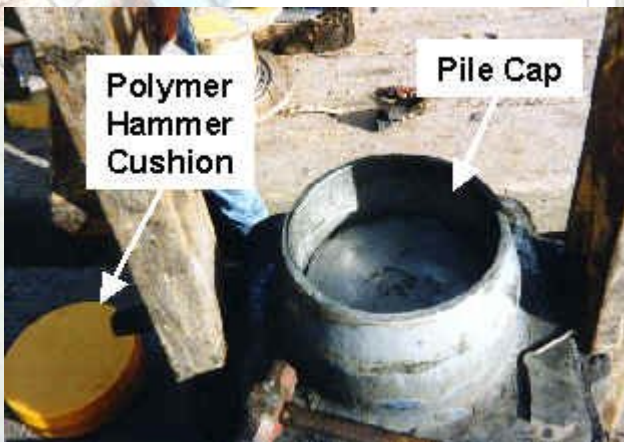

Hammer cushion set in pile cap.

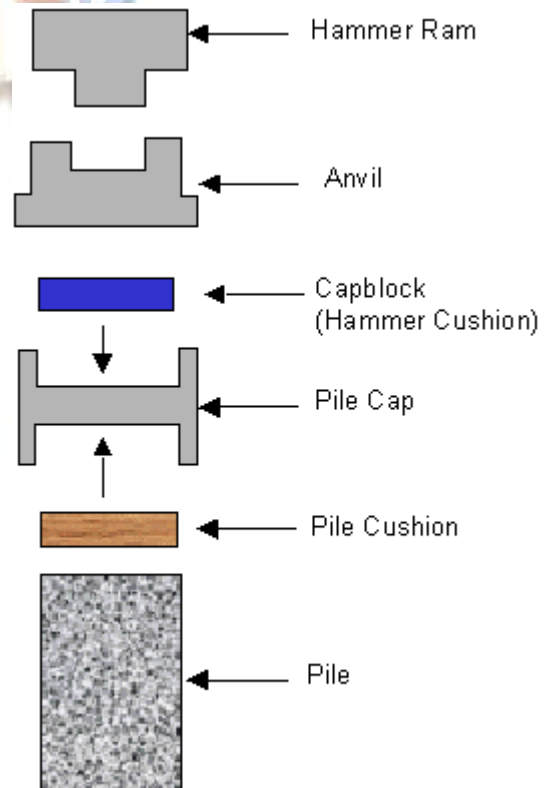

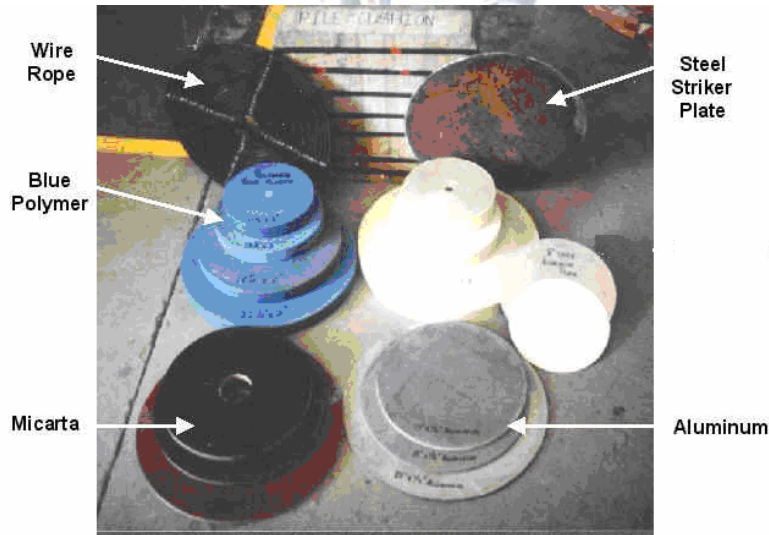

This picture shows some common types of cushions.

For Superior Performance & Reliability, Trust ProDrive® Cushion Pads

- ProDrive® GP
- ProDrive® Oil
- ProDrive® SL

Only from Professional Plastics, Inc.



PROFESSIONAL PLASTICS, INC.

The Nation's Largest Supplier of High Performance Plastic Shapes

(800) 966-PROS or **(281) 879-4500** Fax (281) 879-4502

10641 S. Sam Houston Pkwy W., Bldg. 5, Suite 100

Houston, TX 77071

12 Locations throughout the USA

www.professionalplastics.com

Serving Texas & the Gulf Coast region Since 1984

Information provided herein is courtesy
U.S. Department of Transportation – Federal Highway Administration